

Kingfisher Engines



Darglow House
Upton Cross
Upton
Poole
Dorset
BH16 5PH Telephone: 0202 632309 Fax: 0202 632227

KD14 MARINE DIESEL ENGINE

TECHNICAL DATA

TYPE	HORIZONTAL, TWIN CYLINDER FOUR STROKE, WATER COOLED, INDIRECT INJECTION, WET CYLINDER LINERS
BORE/STROKE	75/80 mm
DISPLACEMENT	797 cc
COMPRESSION RATIO	21.5 : 1
MAX OUTPUT	10.3 KW @ 2600 REV/MIN 14 HP @ 2600 REV/MIN
MAX TORQUE	54 N.m. @ 1750 REV/MIN 40 LBS/FT @ 1750 REV/MIN
COOLING METHOD	RAW WATER CIRC JABSCO PUMP
STARTING METHOD	HAND CRANK & ELECTIC START
FUEL SPECIFIC CONSUMPTON	208 gms/hp.hr
LUBRICATION	PUMP & SPLASH
GEARBOX	HYDRAULIC 2:1 REDUCTION FNR <u>KD14-1</u> MANUAL, 2:1 REDUCTION FNR
DIMENSIONS (LxWxH) mm	762 x 655 x 460
NETT WEIGHT WITH GEARBOX	220 KG

KD 14/2 STANDARD
DRY EXHAUST

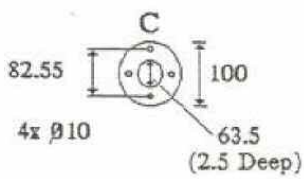
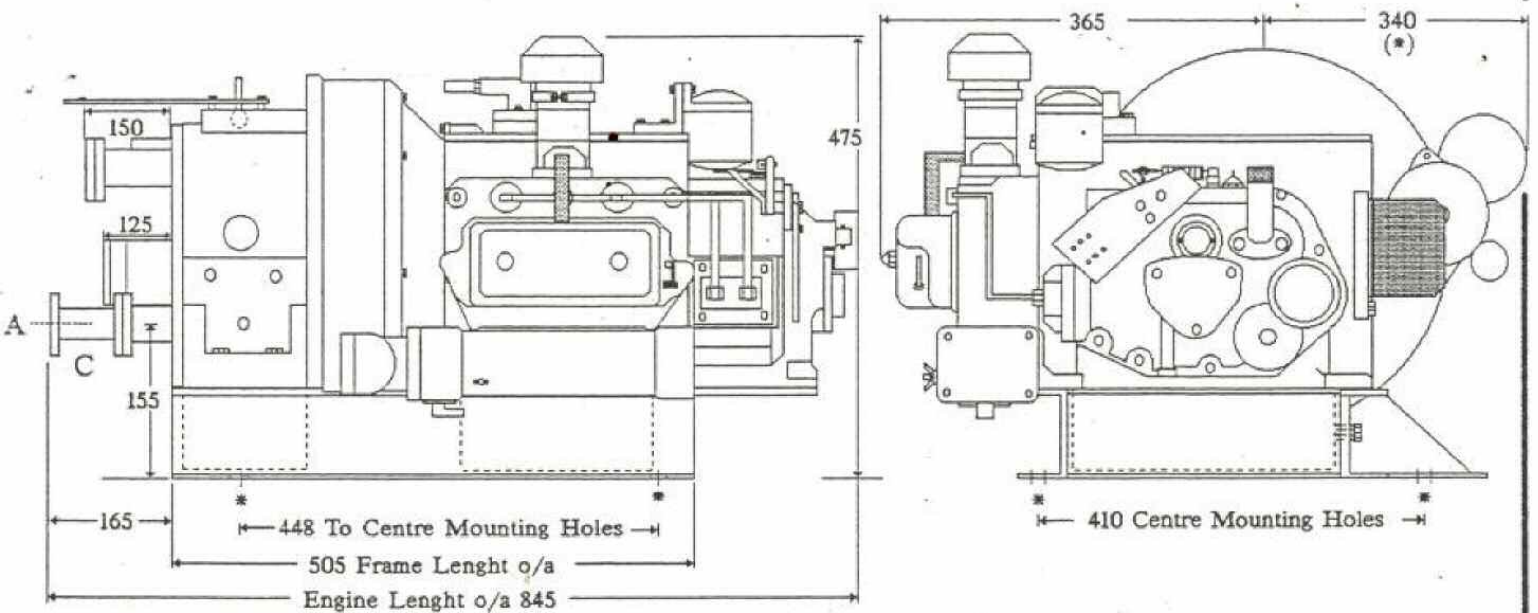

- A - Gearbox Output Shaft Centreline
- Gearbox Output Is Central Between Mounting Points
- * - Engine Rubber Mounts See Drawing
- Engine Dimensions Are The Same For All Options
- (*) Port Side Width of 340 Can be Reduced to 250 (If Required)

Revisions Kingfisher	Engine Installation KD 14/2 - MA100 Gearbox Starboard - Front View	Drawn EM	Traced	Checked	Approved <i>[Signature]</i>	Date 0294
		Drawing No: KD14/2 a				

Kingfisher Engines

Darglow House

Upton Cross

Upton

Poole

Dorset

BH16 5PH Telephone: 0202 632309 Fax: 0202 632227

KD26 MARINE DIESEL ENGINE

TECHNICAL DATA

TYPE	Vertical, Twin Cylinder, Four Stoke, Water Cooled, Indirect Injection, Wet Cylinder Liner
BORE / STROKE	95 / 115 mm
DISPLACEMENT	1630 cc
COMPRESSION RATIO	19 : 1
MAX OUTPUT	19.4 kw @ 2000 REV / MIN 26.4 hp @ 2000 REV / MIN
MAX TORQUE	95 N M @ 1750 REV / MIN 70 LBF / FT @ 1750 REV / MIN
COOLING METHOD	Inland: Keel Cooling Offshore: Indirect with Heat Exchanger & Jabsco Pump
STARTING METHOD	Hand Crank & Electric Start
SPECIFIC FUEL CONSUMPTION	190 gms / hp / hr
LUBRICATION	Pump & Splash
GEARBOX	Hydraulic 2:1 Reduction FNR
DIMENSIONS (LxWxH) mm	950 x 715 x 922
NETT WEIGHT WITH GEARBOX	430 kg Inland 395 kg Offshore

KD 26 OFFSHORE

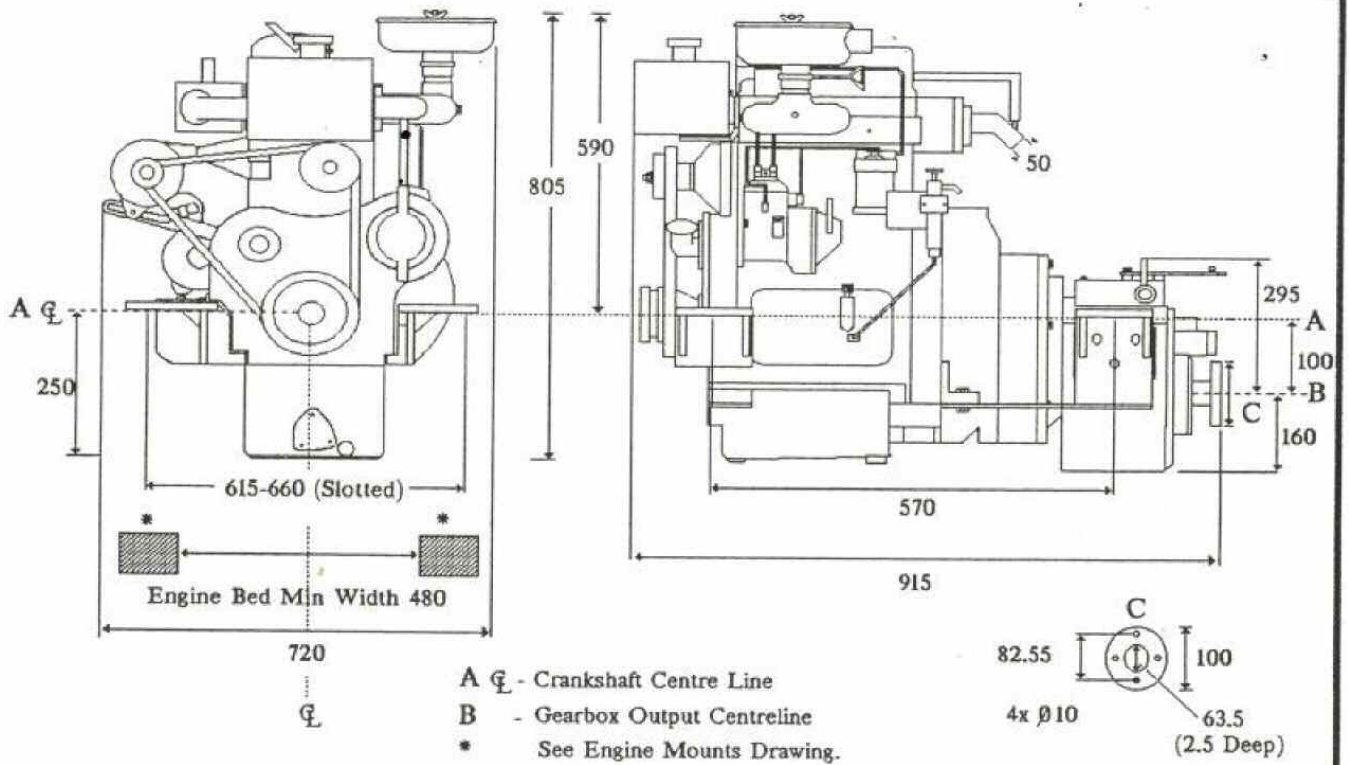

Revisions

Kingfisher

Engine Installation
KD 26 - MA100 Gearbox
 (Offshore)
 (Port Side - Front View)

Drawn
 EM

Traced

Checked
 P.R.

Approved
 P.R.

Date
 0194

Drawing No: KD 26 (Offshore b)